



REGON 82190

FIRE EXTINGUISHER CABINET 12 kg - CO2



External dimensions (mm): 865x335x240

Internal Dimensions (mm): 795x244x204

Weight (kg): 3.2

Ring Diameter (mm): 170/190 e 150/170

Quantity per pallet (n°): 40

Pallets dimensions (cm): 100x120x265

Pallet Weight (kg): 170

TECHNICAL FEATURES

Material: polypropylene, nylon, polycarbonate

Production Process: Injection Molding

Label with company logo

COMPONENTS

- Label in PVC
- Inspection window in polycarbonate
- Nylon clamping ring with PVC spring

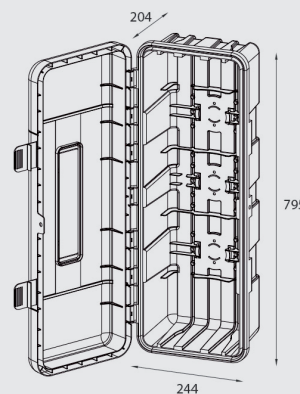
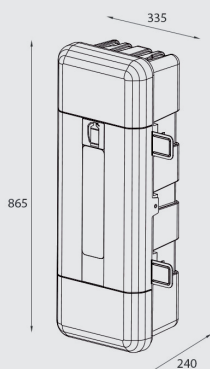

TEST AND CERTIFICATIONS

- TÜV RHEINLAND (7/2012) (IP certificated)

PRODUCT FEATURES

- 1 Double ergonomic handles integrated in the lid, with click-system anti-vibration for security in the everyday use
- 2 The Inspection window allows the view of the fire extinguisher. The "OR" seal guarantees a better water-resistance
- 3 Lockable against burglary or mishandling with a common padlock or with seal
- 4 Labyrinth system against water ingress. Even without seal is it guaranteed against dust and water ingress
- 5 Extinguisher holding kit composed of: PVC clamping spring with 4 holes, and Nylon clamping ring available in two sizes
- 6 Bayonet cap for clamping ring, with reinforced fixing points easy to assemble without any tools
- 7 PVC label (optional) 8x8 cm with extinguisher pictogram and/or company logo according to the law of the country of destination



OPTIONALS

Brackets: 88041, 88042

OPTIONS: Custom resin labels (pictogram and logo)

SPARE PARTS: 89515, 89507, 89506, 89508